

K.S.R.M. COLLEGE OF ENGINEERING (Autonomous), KADAPA.  
B. Tech I Sem (R18) Model Question paper November 2018  
**ENGLISH - I**  
(Common to CE, ME & EEE)

**Time: 3 Hrs.**

**Max Marks : 70**

**Note:** Answer any **FIVE** questions. **All** questions carry equal marks.

**I. Correct any FOURTEEN of the following sentences if necessary** **14x1=14**

- (1) He has two sister-in-laws
- (2) Your service to the society is greater than me
- (3) A.P.J. Abdul Kalam is one of the most greatest philanthropists
- (4) She is one of those who likes classical dance.
- (5) Ten projects were accepted and one rejected.
- (6) He behaved cowardly before his opponent.
- (7) He is always for his boss to get promotion.
- (8) He worked hard and failed.
- (9) He returned the book back to me.
- (10) You worked hard, Isn't it?
- (11) If you ask me I would oblige
- (12) I am going to school everyday
- (13) The teacher taughted me a lesson
- (14) One of my book has been stolen.
- (15) South Indians prefer coffee than tea
- (16) I have not read the book from 2008
- (17) She is my cousin sister.

**II. (A) What is word formation ? Discuss various types of word formation ?** **1x7=7**

**(B) i. Give antonyms of the following.** **3x1=3**

- a) Creator b) important c) adversity

**ii. Give synonyms of the following** **4x1=4**

- a) Peace b) achieve c) abandon d) faith

**III. A) Draft a dialogue between a student and a teacher about improving communication**

skills. **1x7=7**

B) Give the meaning of the idioms and phrases and use them in sentences of your

own. **1x7=7**

- i) crocodile tears ii) give up iii) a snake in the grass iv) to break the ice

- v) make up vi) die of vii) tooth and nail

**IV. A) 1) Make five meaningful sentences on the following pattern.** **1x5= 5**

Subject +	Verb +	Object +	To infinitive
He	helped	me	to push the car

**2) Punctuate the following.** **2M**

in the words of murphys law anything that can go wrong will become wrong

**B. List out the principles of paragraph writing ?**

**7M**

**V. A) Rewrite the following sentences as directed**

**1x7 = 7**

- 1) I got invitation. ( Rewrite the sentence by using 'invitation' as verb )
- 2) He was succeeded in the exams. ( Rewrite the sentence by using 'succeeded' as an adjective )
- 3) She posted the letter. (change into passive voice)
- 4) My purse was stolen. ( change into active voice)
- 5) Who taught you English? (change into passive voice)
- 6) Gita said, "the earth revolves around the sun". ( change into indirect speech)
- 7) He requested me to help the poor. ( change into indirect speech)

**B) Rewrite the following sentences as directed**

**1x7 = 7**

- 1) No other girl is so clever as Manasa. ( change into Superlative Degree )
- 2) A deer runs faster than a horse. ( change into Positive Degree)
- 3) Mumbai is one of the biggest cities in India ( change into Comparative Degree)
- 4) He is poor but he is honest. ( change into Complex sentence)
- 5) He saw a tiger. He ran away. (change into Simple sentence)
- 6) He is too weak to walk. ( change into Compound sentence )
- 7) If you work hard, you will pass the exam. ( change into Simple sentence )

**VI. A) a) Fill in the blanks with suitable articles.**

**3x1= 3**

- i) It is ----- one rupee note.
- ii) He is ----- honest man.
- iii) ----- Ganges is a holy river.

**b) Fill in the blanks with suitable prepositions**

**4x1= 4**

- i) It has been raining ----- 9 a.m
- ii) Sumanth is looking \_\_\_\_\_ the picture.
- iii) She prefers coffee \_\_\_\_\_ juice.
- iv) Raghu goes to college \_\_\_\_\_ foot.

**B) a) Fill in the blanks with the right verb forms from the verbs given in brackets 5x1=5**

- i) He always \_\_\_\_\_ ( like ) music.
- ii) Mokshith \_\_\_\_\_ (do, not) attend the college yesterday.
- iii) I \_\_\_\_\_ ( be ) ill since last Friday.
- iv) Before he reached the station, the train \_\_\_\_\_ already \_\_\_\_\_ (leave).
- v) They \_\_\_\_\_ (play) cricket next week.

**b) Fill in the blanks with suitable conjunctions**

**2x1=2**

- i) \_\_\_\_\_ he worked hard, he failed in the exam.
- ii) Gopal \_\_\_\_\_ Bhupal are brothers.

**VII. A) Read the following passage and answer the questions:**

The progress of a country, now-a-days is assessed in terms of economic development that has been achieved. And the measuring rod of economic development is Gross National Product. To Gandhi it was a foreign concept. GNP is rather a fraud upon the people. An increase in GNP in terms of money does not really mean an equitable distribution of money. He had experienced that even with an increase in national income the poor remain poor. Most of the poor live in villages, rather most of the people, in India, live in villages. Thus, according to Gandhian Economics the hub of production should be village, not city. Howsoever big the industries may be, due to mechanization, they just can't absorb the vast humanity in this country. Large-scale production, is, according to him, alien to the very spirit of rural development as it is capital oriented. Since the people are poor they can organize and run only cottage industries. It is realized by the prominent economists that this Gandhian way is the only solution for the mass unemployment in this country.

**Questions :**

**7x1=7**

- 1) How is the progress of a country measured?
- 2) Expand 'GNP'.
- 3) Why is GNP a fraud upon the people ?
- 4) Why should the hub of production be village?
- 5) Pick out the word from the passage which means 'trickery'.
- 6) Why did Gandhi consider large scale production alien to the spirit of rural development?
- 7) What is the solution for mass unemployment?

**B) Write a précis of the following passage reducing it to one third of its length. 1x7=7**

A great part of Arabia is desert. Here there is nothing but sand and rock. The sand is so hot that you cannot walk over it with your bare feet in the day-time. Here and there in the desert are springs of water that come from deep down under the ground- so deep that the sun cannot dry them up. These springs are few and far apart, but wherever there is one, green grass very soon covers the ground all around it. Soon fig trees and palm trees grow tall and graceful, making a cool, green shady place around the spring. Such a place is called an oasis.

**VIII. A) write an essay of the following in about 250 words.**

**1x7= 7**

- (a) Role of an Engineer in the development of nation

**B) Expand the following into a paragraph.**

**1x7= 7**

- (a) All that glitters is not gold

-----

K.S.R.M. COLLEGE OF ENGINEERING (Autonomous), KADAPA.

B.Tech I Sem (R18) Model Question paper

**Mathematics – I**

**( Common to All Branches)**

Time: 3 Hrs.

Max Marks : 70

Note : Answer any **FIVE** questions by choosing one from each unit.

All questions carry equal marks.

**UNIT - I**

1. a) Determine the rank of the following matrix. (7M)

$$A = \begin{bmatrix} 2 & -1 & 3 & 4 \\ 0 & 3 & 4 & 1 \\ 2 & 3 & 7 & 5 \\ 2 & 5 & 11 & 6 \end{bmatrix}$$

- b) Discuss for what values of  $\lambda$  and  $\mu$  the simultaneous equations  $x + y + z = 6$ ,  $x + 2y + 3z = 10$ ,  $x + 2y + \lambda z = \mu$ , have (i) no solution (ii) a unique solution (iii) an infinite number of solutions. (7M)

(OR)

2. Verify Cayley-Hamilton theorem for the matrix  $A = \begin{bmatrix} 2 & -1 & 1 \\ -1 & 2 & -1 \\ 1 & -1 & 2 \end{bmatrix}$  and find its inverse. (14 M)

**UNIT – II**

3. Test for the convergence of the series

(i)  $\frac{1}{2\sqrt{1}} + \frac{x^2}{3\sqrt{2}} + \frac{x^4}{4\sqrt{3}} + \dots \dots \dots \infty$  (7M)

(ii)  $\frac{1}{2} + \frac{2}{3}x + \left(\frac{3}{4}\right)^2 x^2 + \left(\frac{4}{5}\right)^3 x^3 + \dots \dots \dots \infty$  ( $x > 0$ ) (7M)

(OR)

4. (a) Discuss the convergence of the series  $\frac{2}{1^p} + \frac{3}{2^p} + \frac{4}{3^p} + \frac{5}{4^p} + \dots \dots \dots \infty$  (7M)

- (b) State the values of  $x$  for the which the following series convergent:

$$x - \frac{x^2}{2} + \frac{x^3}{3} - \frac{x^4}{4} + \dots \dots \dots \infty$$
 (7M)

**UNIT – III**

5. a) Prove that  $\log(1 + e^x) = \log 2 + \frac{x}{2} + \frac{x^2}{8} - \frac{x^4}{192} + \dots$  (7M)

b) A window has the form of a rectangle surmounted by a semi-circle. If the perimeter is 40ft, find its dimensions so that the greatest amount of light may be admitted. (7M)

(OR)

6. a) Find the coordinates of the centre of curvature at any point of the parabola  $y^2 = 4ax$ . (7M)

b) Show that the radius of curvature at any point of the cardioid  $r = a(1 - \cos \theta)$  varies as  $\sqrt{r}$ . (7M)

**UNIT – IV**

7. a) If  $u = x^2 - y^2$ ,  $v = 2xy$  and  $x = r \cos \theta$ ,  $y = r \sin \theta$ , find  $\frac{\partial(u,v)}{\partial(r,\theta)}$  (7M)

b) Show that the rectangular solid of maximum volume that can be inscribed in a sphere is a cube. (7M)

(OR)

8. In a plane triangle, find the maximum value of  $\cos A \cos B \cos C$ . (14M)

**UNIT – V**

9. Show that  $\beta(m, n) = \frac{\Gamma(m)\Gamma(n)}{\Gamma(m+n)}$ . (14M)

(OR)

10. a) Find  $f(x) = x^2$  as half range cosine series in  $(0, \pi)$  (7M)

b) Expand  $f(x) = \begin{cases} \frac{1}{4} - x, & \text{if } 0 < x < \frac{1}{2} \\ x - \frac{3}{4}, & \text{if } \frac{1}{2} < x < 1 \end{cases}$  as the Fourier of sine terms. (7M)

**B.Tech. I Semester (R18) Degree Examinations**  
**Programming for Problem Solving Model Question Paper**

Time: 3Hours

(Common to CE, ME and EEE)

Max.Marks:70

---

**Note:** Answer any **FIVE** questions choosing **ONE** question from each unit.  
All questions carry **Equal** marks.

**Unit - I**

1. a) Explain the process of software development life cycle in detail. [7M]  
b) What are formatted input and output functions available in c? Explain with suitable C programs. [7M]

**(OR)**

2. a) What is a variable? Explain rules for writing variables in C? [7M]  
b) Explain various steps involved in creating and running a C program and illustrate it with help of a diagram. [7M]

**UNIT-II**

3. a) Explain the different types of operators available in C [7M]  
b) Explain syntax of **for loop**. Write a C program to find whether a given number is prime number or not using for loop. [7M]

**(OR)**

4. a) Explain the syntax of **while loop**. Write a C program to find sum of individual digits of a given number using while loop. [7M]  
b) Explain the syntax of **if - else statement**. Write a C program to find whether a given number is even or odd. [7M]

**UNIT-III**

5. a) Define array. Explain declaration and initialization of one dimensional arrays with an example. [7M]  
b) Write a C program to sort array elements in ascending order using bubble sort technique. [7M]

**(OR)**

6. a) Define String. Write a C program to find given string is palindrome or not without using string handling functions. [7M]  
b) Write a C program to check whether the entered character is vowel or not. [7M]

**UNIT-IV**

7. a) Define function. Explain the following storage classes used in C with the help of examples.  
i. static            ii. extern [7M]  
b) Define pointer? Explain declaration and initialization of a pointer with an example. [7M]

**(OR)**

8. a) Explain the following parameter passing mechanisms through C programs  
(i) call by value    (ii) call by reference [7M]  
b) What is recursion? Write a C program to find factorial of a given number using recursion. [7M]

**UNIT-V**

9. a) Define structure. Explain how structure members are declared, initialized and accessed using a C program. [7M]  
b) Explain the concept of copying and comparing structure variables [7M]

**(OR)**

10. a) Write a C program to accept the roll number, name and marks obtained in three

tests of three students of a class and display the roll number, name, marks of three tests and their average. [10M]

b) Write the differences between arrays and structures. [4M]

**K.S.R.M COLLEGE OF ENGINEERING, KADAPA  
(AUTONOMOUS)  
MODEL QUESTION PAPER  
FOUR YEAR B. TECH DEGREE EXAMINATIONS  
B.TECH I SEMESTER REGULAR EXAMINATION  
SUB: ENGINEERING CHEMISTRY  
(CIVIL & MEC and EEE)**

**Time : 3hrs**

**Max marks :70**

**Answer any Five questions choosing one question from each unit.**

**UNIT-I**

1. (a) Write notes on particle in one dimensional box.  
(b) Explain crystal field theory and write notes on crystal field splitting in octahedral complexes.

Or

2. (a) Write short notes on LCAO method and explain with a simple example.  
(b) Define doping and explain role of doping in silicon.

**UNIT-II**

3. (a) Write short notes on orbital energies of atoms.  
(b) Explain in detail on electronic configuration.

Or

4. (a) Explain factors influencing Ionisation potential and Electronegativity.  
(b) Explain hard soft acids & bases.

**UNIT-III**

5. (a) Define cell potential and derive Nernst equation.  
(b) Write short notes on Boiler troubles.

Or

6. (a) Define corrosion and explain wet corrosion.  
(b) Write short notes on (i) Ionic interactions (ii) Critical phenomenon.

**UNIT-IV**

7. (a) Define spectroscopy and explain the selection rules in spectroscopy.  
(b) Write short notes on Fluorescence and its applications.

Or



8. Explain vibrational and rotational spectra of diatomic molecules.

**UNIT-V**

9. (a) Write short notes on structural isomers and stereoisomers.

(b) Explain Baeyer-villiger reaction.

Or

10. (a) Write short notes on enantiomers and diastomers.

(b) Explain addition reactions involving C=O (Grignard reagent).

**K.S.R.M COLLEGE OF ENGINEERING (AUTONOMOUS), KADAPA**

**B.Tech II Sem R-18 (CE/ME Only)**

**Model Paper**

**SUB: BASIC ELECTRICAL ENGINEERING (1802205)**

**Time: 3 hours**

**Max Marks: 70 M**

Note: 1. Answer any **FIVE** questions by Choosing **ONE** Question from each Unit

2. All questions carry Equal Marks

**Unit-1**

1. a) Determine Current passing through  $2\Omega$  Resistance for the given circuit shown in figure

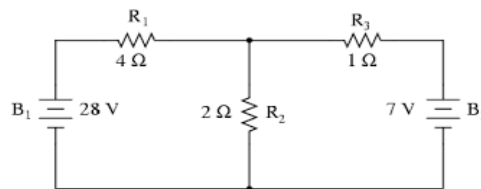

- b) Find the Resistance between A and B

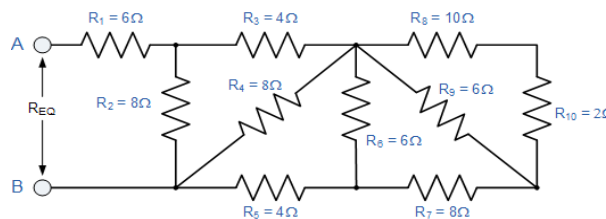

(or)

2. Derive the equation of star (Y) to delta( $\Delta$ ) transformation.

**Unit-2**

3. a) Define the following terms for sinusoidal form  
a) Average value, b) RMS values, c) form factor and d) peak factor

- b) Find the form factor of the half-wave rectified sine wave



(or)

4. A given load consisting of a resistor R and a capacitor C, take a power of 4800W from 200V, 60Hz Supply mains. Given that the voltage drop across the resistor is 120V Calculate the a) impedance, b) current, c) power factor d) resistance, e) capacitance. Write down the equations for the current and voltage.

**Unit-3**

5. (a) Explain the working principle and constructional details of DC Generator With a neat Sketch.  
(b) Derive the EMF equation of DC Generator.

(or)

6. a) Write about different types of DC Motors.  
b) Derive the Torque equation of DC Motor.

**Unit-4**

7. a) Explain the construction and working principle of single phase transformer.  
b) Derive the EMF equation of single phase transformer.

(or)

8. a) Explain Construction and working principle of 3- $\phi$  Induction motor with a neat Sketch i) Squirrel cage ii) Slip ring.  
b) The power input to the rotor of a 3- $\phi$ , 50Hz, 6-Pole IM is 80KW, the Rotor EMF makes 120 complete alternations per minute. Find a) Slip b) Motor Speed.

**Unit-5**

9. Write a short note on switch fuse unit (SFU) and miniature circuit breaker

(or)

10. Explain about different types of cables and significance of Earthing.

**K.S.R.M. COLLEGE OF ENGINEERING,(AUTONOMOUS),KADAPA  
B.Tech II sem EEE (R18)**

**Model Paper**

**Sub: BASIC ELECTRICAL ENGINEERING (1802206)**

**Time:180 Min**

**Max Marks 70**

**Note: Answer all Questions . Each Question carries equal marks.**

**UNIT-I**

- 1.a) Explain the types of energy sources in electrical circuits.
- b). Determine the equivalent resistance between the terminals a-b for the network given below.

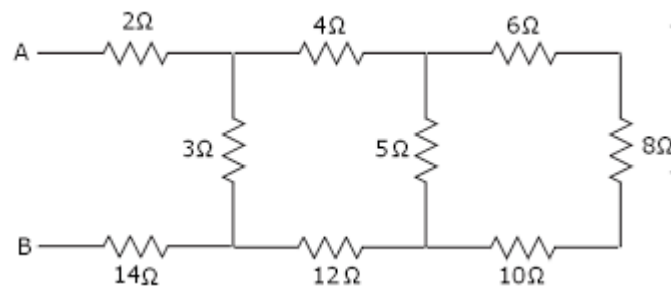

(OR)

2. a) Explain Kirchhoff's laws.
- b). Determine node voltages for the network shown below.

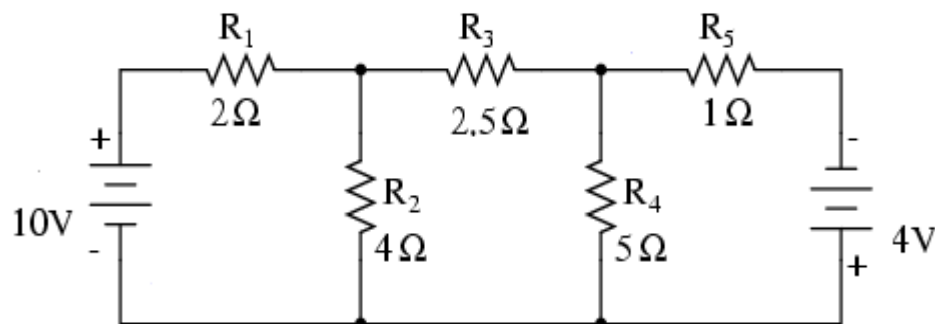

**UNIT-II**

3. a). State maximum power transfer theorem and obtain the condition to obtain maximum power.
- b) Determine the Norton's equivalent network for circuit given below.

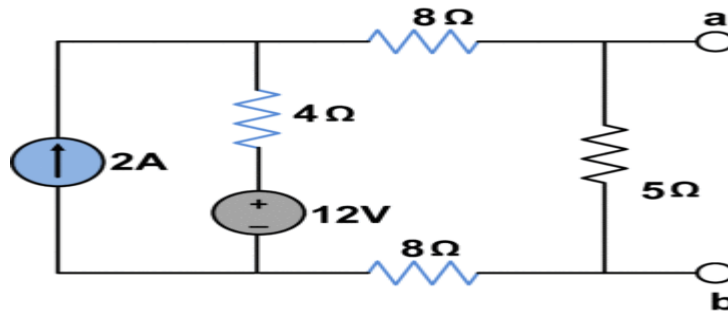

(OR)

4. a) State and explain Thevenin's Theorem .

b). Determine current in 10 ohms resistor using superposition theorem for the network shown below.

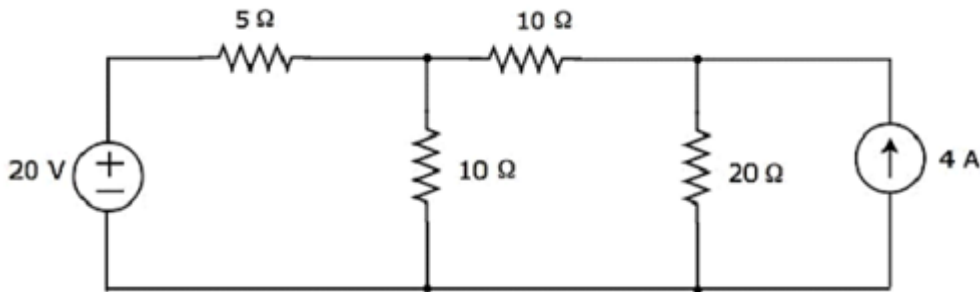

### UNIT-III

5. a) Define RMS and Average values and determine for a sinusoidal waveform.

b) A circuit having a resistance of  $20\Omega$  and inductance of  $0.07\text{H}$  is connected in parallel with a series combination of  $50\Omega$  resistance and  $60\mu\text{F}$  capacitance. Calculate the total current, when the parallel combination is connected across  $230\text{V}$ ,  $50\text{Hz}$  supply.

(OR)

6 a). Show that average power through pure inductor is equal to zero.

b).An impedance coil in parallel with a  $100\mu\text{F}$  capacitor is connected across a  $200\text{V}$ ,  $50\text{Hz}$  supply. The coil takes a current of  $4\text{A}$  and the power loss in the coil is  $600\text{W}$ . Calculate (i) the resistance of the coil (ii) the inductance of the coil (iii) the power factor of the entire circuit.

### UNIT-IV

7.a) Define self and mutual inductances and determine coefficient of coupling for the single phase transformer.

b).Explain dot convention.

(OR)

8. a) Explain the procedure to form dual network with some dual pairs.

b) Obtain the dual network for the network shown below.

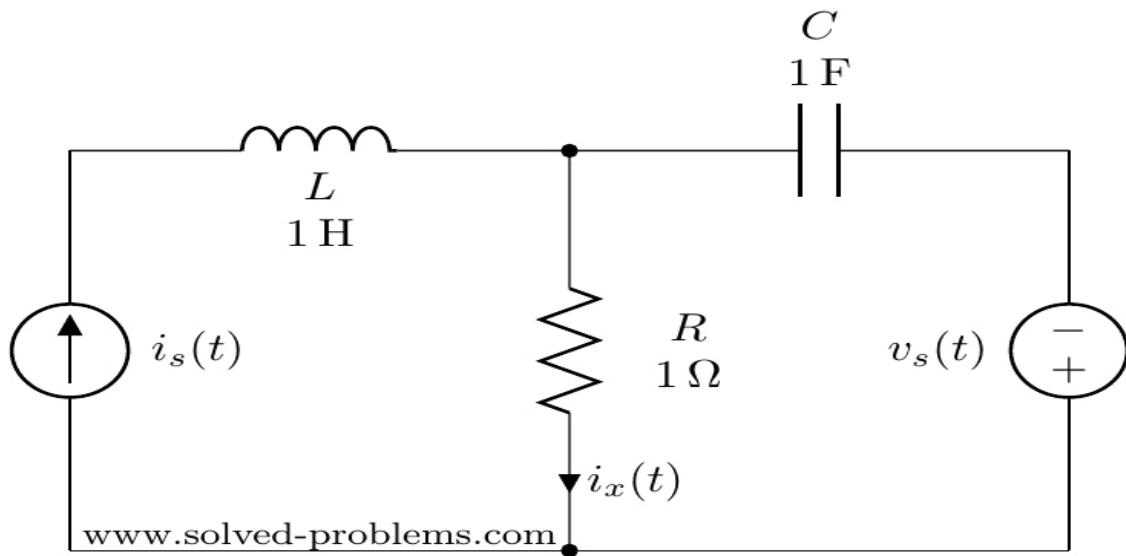

### UNIT-V

9. For the network shown below draw the graph and write the incidence matrix and determine the number of possible trees.

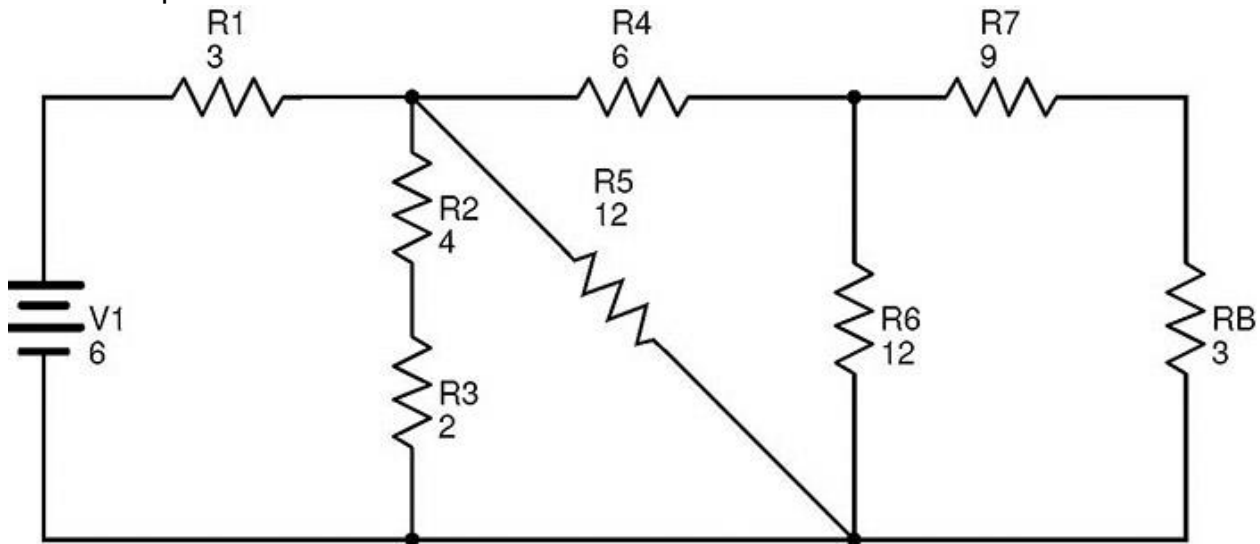

(OR)

10. Obtain the fundamental tie-set matrix and write the necessary equilibrium equation for the graph given below. Select 2,3,6 as tree branches.

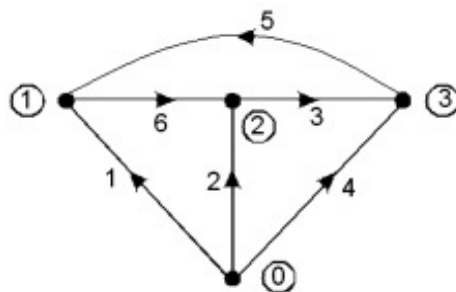

**Subject Code: 1823202 /R18**

**K.S.R.M COLLEGE OF ENGINEERING, KADAPA  
(AUTONOMOUS)  
MODEL QUESTION PAPER  
FOUR YEAR B. TECH DEGREE EXAMINATIONS  
I B.TECH II SEMESTER REGULAR EXAMINATION  
SUB: ENGINEERING CHEMISTRY  
(ECE & CSE)**

**Time : 3hrs**

**Max marks :70**

**Answer any Five questions choosing one question from each unit.**

**UNIT-I**

1. (a) Write notes on particle in one dimensional box.  
(b) Explain crystal field theory and write notes on crystal field splitting in octahedral complexes.

Or

2. (a) Write short notes on LCAO method and explain with a simple example.  
(b) Define doping and explain role of doping in silicon.

#### UNIT-II

3. (a) Write short notes on orbital energies of atoms.  
(b) Explain in detail on electronic configuration.

Or

4. (a) Explain factors influencing Ionisation potential and Electronegativity.  
(b) Explain hard soft acids & bases.

#### UNIT-III

5. (a) Define cell potential and derive Nernst equation.  
(b) Write short notes on Boiler troubles.

Or

6. (a) Define corrosion and explain wet corrosion.  
(b) Write short notes on (i) Ionic interactions (ii) Critical phenomenon.

#### UNIT-IV

7. (a) Define spectroscopy and explain the selection rules in spectroscopy.  
(b) Write short notes on Fluorescence and its applications.

Or

8. Explain vibrational and rotational spectra of diatomic molecules.

#### UNIT-V

9. (a) Write short notes on structural isomers and stereoisomers.  
(b) Explain Baeyer-villiger reaction.

Or

10. (a) Write short notes on Enantiomers and diastomers.  
(b) Explain addition reactions involving C=O (Grignard reagent).

K.S.R.M. COLLEGE OF ENGINEERING(Autonomous):: KADAPA

B.Tech II-Sem (R18 - UG)

Model Question Paper (2018-2019)

Sub: Engineering Physics

Time: **3 hrs.**

( Common to CE )

Max. Marks: 70

---

Answer any FIVE questions choosing *one* question from each unit.

#### UNIT – I

- 1 a. Explain the interference of light due to thin films by reflection? 10M  
b. A parallel beam of light of  $6000\text{\AA}$  is incident on a thin glass plate of refractive



index 1.5. Such that the angle of refraction in to the glass plate is  $50^\circ$ . Find the least thickness of glass plate which will appear dark by reflection? 04M

( or )

- 2 a. Describe Fraunhofer diffraction due to double slit? 10M  
b. Write any four applications of diffraction ? 04M

### UNIT – II

- 3 a. Distinguish between spontaneous and stimulated emission? 06M  
b. Derive the relation between various Einstein's coefficients? 08M

( or )

- 4 a. Explain the construction and working of semiconductor diode Laser? 10M  
b. Write any four applications of lasers? 04M

### UNIT – III

- 5 a. Derive the formal solution of kinematical equations? 08M  
b. Explain the velocity and acceleration in polar co-ordinates? 06M

( or )

6. a. Write the applications of Newton's laws? 06M  
b. Explain the conservative and non-conservative forces ? 08M

### UNIT – IV

- 7 a. Derive the kinematics in a co-ordinate system rotating and translating in the plane? 07M  
b. Explain the angular momentum about a point of a rigid body in planar motion? 07M

( or )

- 8 a. Explain the Euler's laws of motion? 06M  
b. Describe the impedance from Newton's laws and their necessity in describing rigid body motion? 08M

### UNIT – V

- 9 a. Describe the electrical conductivity in metals using classical free electron theory? 10M  
b. Explain the origin of energy bands in solids? 04M

( or )

- 10 a. Derive the expressions for intrinsic carrier concentration and Fermi level in intrinsic semiconductor? 10M  
b. Distinguish between direct and indirect band gap semiconductors? 04

**Time: 3 hrs.**

( Common to EEE )

**Max. Marks: 70**

---

**Answer any FIVE questions choosing *one* question from each unit.**

**UNIT – I**

- 1 a. Define simple harmonic oscillator? Derive the equation for energy of simple harmonic oscillator? 10M  
b. Write any four characteristics of simple harmonic oscillator 4M  
( or )
- 2 a. Derive the equation for energy and power dissipations in damped Harmonic oscillations? 10M  
b. Define Resonance? Write any two examples of resonance? 4M

**UNIT – II**

- 3 a. Explain the theory of Newton's rings experiment? 10M  
b. In a Newton's rings experiment, the diameter of the 5<sup>th</sup> ring is 0.30cm and 15<sup>th</sup> ring is 0.62cm. Find the diameter of the 25<sup>th</sup> ring? 4M  
( or )
4. a. Describe Fraunhofer diffraction due to N-slits? 10M  
b. Write any four differences between interference and diffraction? 4M

**UNIT – III**

5. a. Explain the construction and working of Nd-YAG Laser? 10M  
b. Derive the relation between various Einstein's coefficients? 4M  
( or )
6. a. Explain the construction and working of Semiconductor diode Laser? 10M  
b. Write any eight applications of Lasers? 4M

**UNIT – IV**

- 7 a. Derive Schrodinger's time independent wave equation. 10 M  
b. Write about uncertainty principal? 4M  
( or )
- 8 Describe the behavior of a particle in a one-dimensional infinite potential well in terms of its Eigen values and functions? 14M

**UNIT – V**

- 9 Describe Kronig-Penny model to understand the behavior of electrons? 14M  
( or )
- 10 a. Derive the expression for charge density due to drift and diffusion processes? 10M  
b. Write about direct and indirect band gap semiconductors? 4M

**K.S.R.M. COLLEGE OF ENGINEERING( Autonomous):: KADAPA**  
**B.Tech I Sem (R18 - UG)**  
**Model Question Paper**  
**(2018-2019)**  
**Sub: Engineering Physics**

**Time: 3 hrs.**

( Common to ME )

**Max. Marks: 70**

---

Answer any ***FIVE*** questions choosing *one* question from each unit.

**UNIT – I**

- |   |   |     |
|---|---|-----|
| 1 | a. Explain the theory of Young's double slit experiment?  | 10M |
|   | b. A soap film with a refractive index of 1.33 and thickness of $5000\text{\AA}$ is exposed to white light. What wave lengths in the visible region are reflected | 04M |

**( OR )**

- |    |  |     |
|----|--|-----|
| 2. | a. Describe Fraunhofer diffraction due to Single slit?     | 10M |
|    | b. Distinguish between Fresnel's & Fraunhofer diffraction? | 04M |

**UNIT – II**

- |    |   |     |
|----|---|-----|
| 3. | a. Describe the different characteristics of laser?             | 06M |
|    | b. Derive the relation between various Einstein's coefficients? | 08M |

( OR)

4. a. Explain the construction and working of He-Ne Laser? 10M  
b. Write any eight applications of Lasers? 04M

**UNIT – III**

5. a. Describe the mechanical & electrical Simple Harmonic Oscillators? 10M  
b. Define energy decay in Damped Harmonic Oscillator? 04M

( OR)

6. a. Describe the forced mechanical & electrical oscillators? 10M  
b. Explain electrical & mechanical impedance? 04M

**UNIT – IV**

7. a. Define the transverse wave on a string & wave equation of transverse waves on a string? 10M  
b. Explain the harmonic waves? 04M

( OR)

8. a. Describe the standing waves and their Eigen frequencies? 10M  
b. Explain the longitudinal wave on the wave equations? 04M

**UNIT – V**

9. Describe the electrical conductivity in metals using classical free electron theory? 14M

( OR)

10. a. Derive the expression for charge density due to drift and diffusion processes? 10M  
b. Write about direct and indirect band gap semiconductors? 4M

K.S.R.M. COLLEGE OF ENGINEERING (Autonomous), KADAPA.

B.Tech II Sem (R18) Model Question paper APRIL/MAY- 2019

**ENGLISH - I**

(Common to E.C.E & C.S.E)

**Time: 3 Hrs.**

**Max Marks : 70**

**Note:** Answer any **FIVE** questions. **All** questions carry equal marks.

**I. Correct any FOURTEEN of the following sentences if necessary** 14x1=14

- (1) He has two sister-in-laws
- (2) Your service to the society is greater than me
- (3) A.P.J. Abdul Kalam is one of the most greatest philanthropists
- (4) She is one of those who likes classical dance.
- (5) Ten projects were accepted and one rejected.
- (6) He behaved cowardly before his opponent.
- (7) He is always for his boss to get promotion.
- (8) He worked hard and failed.

- (9) He returned the book back to me.
- (10) You worked hard, Isn't it?
- (11) If you ask me I would oblige
- (12) I am going to school everyday
- (13) The teacher teached me a lesson
- (14) One of my book has been stolen.
- (15) South Indians prefer coffee than tea
- (16) I have not read the book from 2008
- (17) She is my cousin sister.

**II. (A) What is word formation ? Discuss various types of word formation ?** **1x7=7**

**(B) i. Give antonyms of the following.** **3x1=3**

- a) Creator b) important c) adversity

**ii. Give synonyms of the following** **4x1=4**

- a) Peace b) achieve c) abandon d) faith

**III. A) Draft a dialogue between a student and a teacher about improving communication skills.** **1x7=7**

**B) Give the meaning of the idioms and phrases and use them in sentences of your own.** **1x7=7**

- i) crocodile tears ii) give up iii) a snake in the grass iv) to break the ice
- v) make up vi) die of vii) tooth and nail

**IV. A) 1) Make five meaningful sentences on the following pattern.** **1x5= 5**

Subject +	Verb +	Object +	To infinitive
He	helped	me	to push the car

**2) Punctuate the following.** **2M**

in the words of murphys law anything that can go wrong will become wrong

**B. List out the principles of paragraph writing ?** **7M**

**V. A) Rewrite the following sentences as directed** **1x7 = 7**

- 8) I got invitation. ( Rewrite the sentence by using 'invitation' as verb )
- 9) He was succeeded in the exams. ( Rewrite the sentence by using 'succeeded' as an adjective )
- 10) She posted the letter. (change into passive voice)
- 11) My purse was stolen. ( change into active voice)
- 12) Who taught you English? (change into passive voice)
- 13) Gita said, "the earth revolves around the sun". ( change into indirect speech)
- 14) He requested me to help the poor. ( change into indirect speech)

**B) Rewrite the following sentences as directed** **1x7 = 7**

- 8) No other girl is so clever as Manasa. ( change into Superlative Degree )
- 9) A deer runs faster than a horse. ( change into Positive Degree)
- 10) Mumbai is one of the biggest cities in India ( change into Comparative Degree)

- 11) He is poor but he is honest. ( change into Complex sentence)  
 12) He saw a tiger. He ran away. (change into Simple sentence)  
 13) He is too weak to walk. ( change into Compound sentence )  
 14) If you work hard, you will pass the exam. ( change into Simple sentence )

**VI. A) a) Fill in the blanks with suitable articles. 3x1= 3**

- i) It is ----- one rupee note.  
 ii) He is ----- honest man.  
 iii) ----- Ganges is a holy river.

**b) Fill in the blanks with suitable prepositions 4x1= 4**

- vi) It has been raining ----- 9 a.m  
 vii) Sumanth is looking \_\_\_\_\_ the picture.  
 viii) She prefers coffee \_\_\_\_\_ juice.  
 ix) Raghu goes to college \_\_\_\_\_ foot.

**B)a) Fill in the blanks with the right verb forms from the verbs given in brackets 5x1=5**

- i) He always \_\_\_\_\_ ( like ) music.  
 ii) Mokshith \_\_\_\_\_ (do, not) attend the college yesterday.  
 iii) I \_\_\_\_\_ ( be ) ill since last Friday.  
 iv) Before he reached the station, the train \_\_\_\_\_ already \_\_\_\_\_ (leave).  
 x) They \_\_\_\_\_ (play) cricket next week.

**b) Fill in the blanks with suitable conjunctions 2x1=2**

- iii) \_\_\_\_\_ he worked hard, he failed in the exam.  
 iv) Gopal \_\_\_\_\_ Bhupal are brothers.

**VII. A) Read the following passage and answer the questions:**

The progress of a country, now-a-days is assessed in terms of economic development that has been achieved. And the measuring rod of economic development is Gross National Product. To Gandhi it was a foreign concept. GNP is rather a fraud upon the people. An increase in GNP in terms of money does not really mean an equitable distribution of money. He had experienced that even with an increase in national income the poor remain poor. Most of the poor live in villages, rather most of the people, in India, live in villages. Thus, according to Gandhian Economics the hub of production should be village, not city. Howsoever big the industries may be, due to mechanization, they just can't absorb the vast humanity in this country. Large-scale production, is, according to him, alien to the very spirit of rural development as it is capital oriented. Since the people are poor they can organize and run only cottage industries. It is realized by the prominent economists that this Gandhian way is the only solution for the mass unemployment in this country.

**Questions : 7x1=7**

- 8) How is the progress of a country measured?  
 9) Expand 'GNP'.  
 10) Why is GNP a fraud upon the people ?  
 11) Why should the hub of production be village?  
 12) Pick out the word from the passage which means 'trickery'.  
 13) Why did Gandhi consider large scale production alien to the spirit of rural development?  
 14) What is the solution for mass unemployment?

**B) Write a précis of the following passage reducing it to one third of its length. 1x7=7**

A great part of Arabia is desert. Here there is nothing but sand and rock. The sand is so hot that you cannot walk over it with your bare feet in the day-time. Here and there in the desert are springs of water that come from deep down under the ground- so deep that the sun cannot dry them up. These springs are few and far apart, but wherever there is one, green grass very soon covers the ground all around it. Soon fig trees and palm trees grow tall and graceful, making a cool, green shady place around the spring. Such a place is called an oasis.

**VIII. A) write an essay of the following in about 250 words.**

**1x7= 7**

(a) Role of an Engineer in the development of nation

**B) Expand the following into a paragraph.**

**1x7= 7**

(a) All that glitters is not gold

-----

**K.S.R.M. COLLEGE OF ENGINEERING (Autonomous), KADAPA.**

**B.Tech II Sem (R18) Model Question paper**

**Mathematics – II**

**( Common to All Branches)**

**Time: 3 Hrs.**

**Max Marks : 70**

---

Note : Answer any **FIVE** questions by choosing one from each unit.

All questions carry equal marks.

**UNIT - I**

1. a) Solve  $(1 + y^2) dx = (\tan^{-1} y - x) dy$  (7M) b)  
Solve  $(x^2y - 2xy^2) dx - (x^3 - 3x^2y) dy = 0$  (7 M)

(OR)

2. A body originally at  $80^\circ C$  cools down to  $60^\circ c$  in 20 minutes, the temperature of the air being  $40^\circ c$ . What will be the temperature of the body after 40 minutes from the original? (14M)

**UNIT - II**

3. Solve  $(D - 2)^2 y = 8(x^2 + e^{2x} + \sin 2x)$ . (14 M)

(OR)

4. Solve  $y'' - 2y' + y = e^x \log x$  by the method of variation of parameters. (14M)

**UNIT - III**

5. (a) Evaluate  $L \left\{ \frac{1-e^t}{t} \right\}$  (7M)

- (b) Find the Laplace transform of the function  $f(t) = \begin{cases} E \sin wt, & 0 < t < \frac{\pi}{w} \\ 0 & , \frac{\pi}{w} < t < \frac{2\pi}{w} \end{cases}$  (7M)

(OR)

6. Solve  $\frac{d^2x}{dt^2} + 9x = \cos 2t$ , if  $x(0) = 1, x(\pi/2) = -1$  by using Laplace Transforms Method. (14M)

**UNIT - IV**

7. Change the order of integration in  $I = \int_0^1 \int_{x^2}^{2-x} xy \, dx \, dy$  and hence evaluate the same. (14M)

(OR)

8. Evaluate  $\int_1^e \int_1^{\log y} \int_1^{e^x} \log z \, dz \, dx \, dy$ . (14M)

**UNIT - V**

9. (a) Find a unit vector normal to the surface  $xy^3z^2 = 4$  at the point  $(-1, -1, 2)$ . (7M)

- (b) Show that  $\text{div}(\text{grad} r^n) = n(n+1)r^{n-2}$ . (7M)

(OR)

10. Verify the Green's theorem for  $\int_c [(xy + y^2)dx + x^2dy]$  where  $c$  is bounded by  $y = x$  and  $y = x^2$ . (14M)



**K.S.R.M.COLLEGE OF ENGINEERING (AUTONOMOUS), KADAPA**

**I B.TECH I SEM (R18) DEGREE EXAMINATION SUB:**

**(1805204) Programming for Problem Solving**

**Model Question Paper**

Time: 3Hours

(Common to CSE and ECE)

Max.Marks:70

---

**Note:** Answer any **FIVE** questions choosing **ONE** question from each unit.  
All questions carry **Equal** marks.

**UNIT-I**

6. a) Explain the process of software development life cycle in detail. 7M  
b) What are formatted input and output functions available in c? Explain with suitable C programs. 7M

**OR**

7. a) What is a variable? Explain rules for writing variables in C? 7M  
b) Explain various steps involved in creating and running a C program and illustrate it with help of a diagram. 7M

**UNIT-II**

8. a) Explain the different types of operators available in C 7M  
b) Explain syntax of **for loop**. Write a C program to find whether a given number is prime number or not using for loop. 7M

**OR**

9. a) Explain the syntax of **while loop**. Write a C program to find sum of individual digits of a given number using while loop. 7M  
b) Explain the syntax of **if - else statement**. Write a C program to find whether a given number is even or odd. 7M

**UNIT-III**

10. a) Define array. Explain declaration and initialization of one dimensional arrays with an example. 7M  
b) Write a C program to sort array elements in ascending order using bubble sort technique. 7M

**OR**

6. a) Define String. Write a C program to find given string is palindrome or not without using string handling functions. 7M  
b) Write a C program to check whether the entered character is vowel or not. 7M

**UNIT-IV**

11. a) Define function. Explain the following storage classes used in C with the help of examples.  
i. static      ii. extern 7M  
b) Define pointer? Explain declaration and initialization of a pointer with an example. 7M

**OR**

12. a) Explain the following parameter passing mechanisms through C programs.  
(i) call by value      (ii) call by reference 7M  
b) What is recursion? Write a C program to find factorial of a given number using recursion. 7M

**UNIT-V**

13. a) Define structure. Explain how structure members are declared, initialized and accessed using a C program. 7M  
b) Explain the concept of copying and comparing structure variables. 7M

**OR**

14. a) Write a C program to accept the roll number, name and marks obtained in three tests of three students of a class and display the roll number, name, marks of three tests and their average.  
b) Write the differences between arrays and structures.

10 M  
4M

**Subject Code: 1801304**

**R 18**

**K S R M College of Engineering (Autonomous), KADAPA – 516 003 B.**  
**Tech 3<sup>rd</sup> Semester Regular Examinations (R-18) Model Paper 2021 Sub:**  
**ENGINEERING MECHANICS**  
**(Civil Engineering)**

**Time: 03:00 Hrs.**

**Max. Marks: 70**

**Answer any FIVE questions choosing one question from each unit**  
**All questions carry Equal Marks**

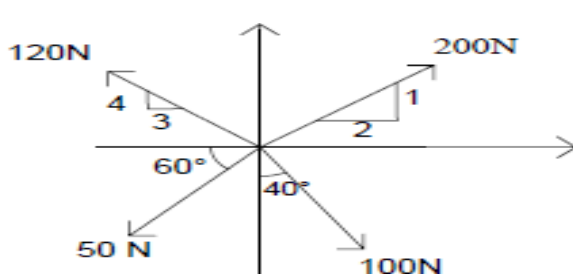
S. No.	QUESTION	Marks
	<b>Unit – I</b>	
1	a) How do you classify force system? b) A system of four forces acting on a body is as shown in the figure below. Determine the resultant of given force system. 	7 7
	<b>OR</b>	

2

a) State and prove Varignon's theorem.

7

b) A fine light string  $ABCDE$  whose extremity  $A$  is fixed, has weights  $W_1$  and  $W_2$  attached to it at  $B$  and  $C$ . It passes round a small smooth peg at  $D$  carrying a weight of  $40\text{N}$  at the free end  $E$  as shown in fig. If in the position of equilibrium,  $BC$  is horizontal and  $AB$  and  $CD$  makes  $150^\circ$  and  $120^\circ$  with  $BC$ , find (i) Tension in the portion  $AB$ ,  $BC$  and  $CD$  of the string and (ii) Magnitude of  $W_1$  and  $W_2$ .

7

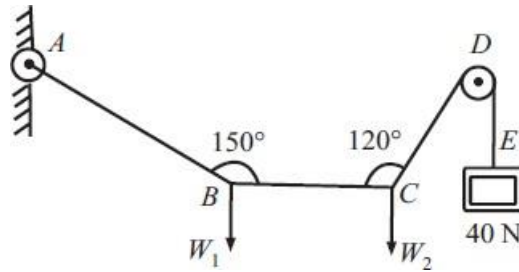

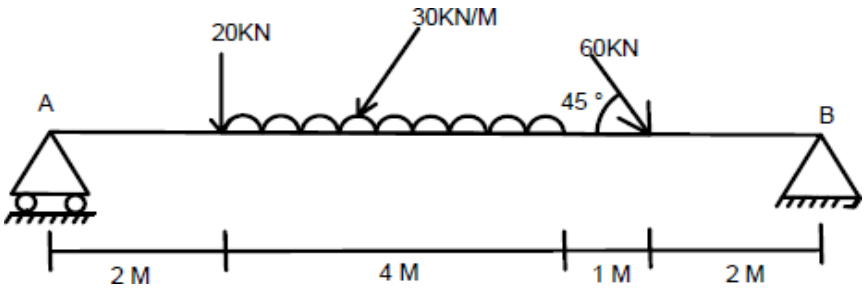
	<b>Unit – II</b>	
3	<p>a) Explain the laws of solid friction.</p> <p>b) A body of weight 500N is pulled up by an inclined plane by a force of 350N. The inclination of plane is 30 degree to the horizontal and the force is applied parallel to the plane. Determine the coefficient of friction.</p>	7 7
	OR	
4	<p>a) Explain how a wedge is used for raising heavy loads. Also gives principle.</p> <p>b) A ladder 5m long rests on a horizontal ground and leans against a smooth vertical wall at an angle <math>70^\circ</math> with the horizontal. The weight of the ladder is 900N and acts at its middle. The ladder is at the point of sliding, when a man weighing 750N stands 1.5m from the bottom of the ladder. Calculate coefficient of friction between the ladder and the floor.</p>	4 10
	<b>Unit – III</b>	
5	<p>a) Find the reactions at supports A and B of loaded beam shown in figure.</p>  <p>b) A simply supported beam AB of 7m span is subjected to (i) 4kNm clockwise couple at 2m from A (ii) 8kNm anticlockwise couple at 5m from A and a triangular load with zero intensity at 2m from A is increasing to 4kN/m at a point 5m from A. determine the reaction at A and B.</p>	7 7
	OR	
6	Determine the forces in all the members of truss shown in the figure. All the inclined members are 60 degrees to horizontal and length of each member is 2 m.	14

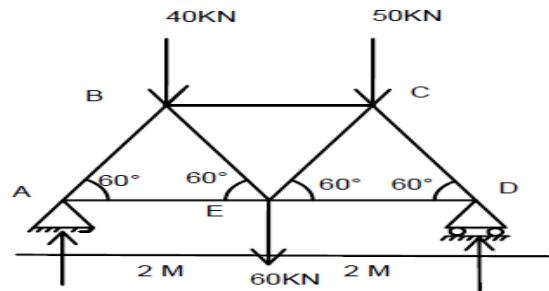

**Unit – IV**

7 Find the centroid of the section given below.

14

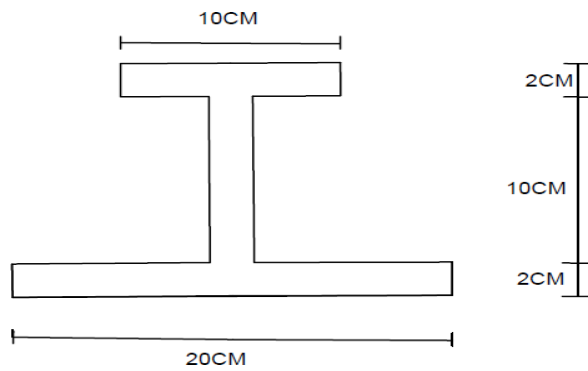

OR

8 Locate the centroid of the shaded area.

14

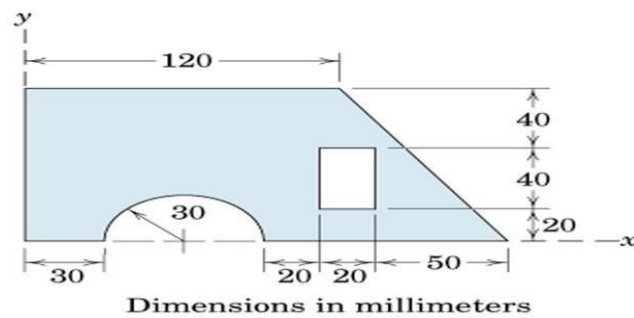

**Unit - V**

9. a) State and prove parallel axis theorem.

7

b) Determine the coordinate of the center of gravity of object, about the x axis.

7

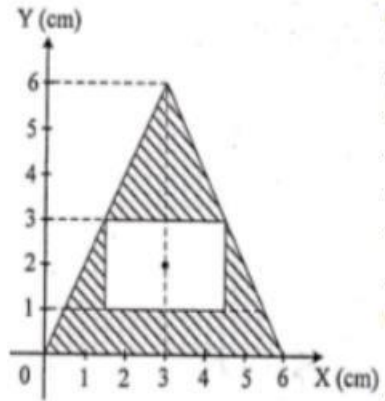

OR

10. Determine the moment of inertia and the radius of gyration of the area shown in the fig.

14

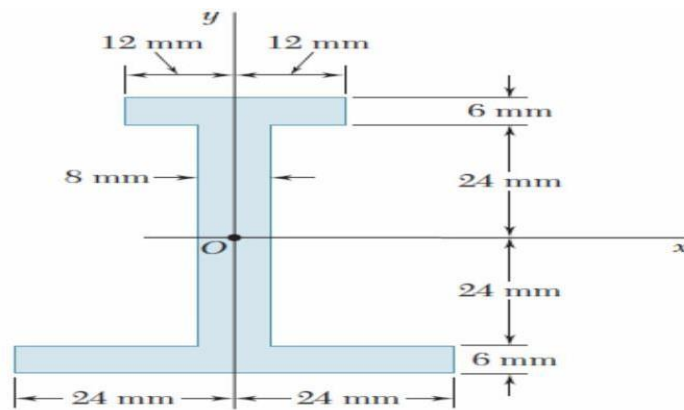

**K S R M College of Engineering (Autonomous), KADAPA – 516 003**  
**B. Tech III Semester Regular Examinations, Model Question Paper- 2021**  
**Sub: Surveying & Geomatics**  
**(Civil Engineering)**

Time: 03:00 Hrs.

Max.

Marks: 70

**Note: Answer All Questions. Each question will carry equal marks**

<b>UNIT – I</b>																				
1 a)	What are different types of obstacles in chain survey? Describe them with neat sketches?	7																		
b)	To determine the width of a river ,a chain line PQR was laid across it, the points was at the points Q and R being on two sides of river. From point S, 60m from Q on line QS which $280^{\circ}$ and $190^{\circ}$ respectively. If the distance PQ was 32m, determine the distance QR and draw the sketch.	7																		
<b>(Or)</b>																				
2 a)	What are the sources of errors in compass?	6																		
b)	The following are the observed bearings of the lines of a traverse ABCDEA with a compass in a plane where local attraction was suspected.	8																		
	<table style="margin-left: auto; margin-right: auto;"> <thead> <tr> <th>LINE</th> <th>FB</th> <th>BB</th> </tr> </thead> <tbody> <tr> <td>AB</td> <td><math>191^{\circ}45'</math></td> <td><math>13^{\circ}0'</math></td> </tr> <tr> <td>BC</td> <td><math>39^{\circ}30'</math></td> <td><math>222^{\circ}30'</math></td> </tr> <tr> <td>CD</td> <td><math>22^{\circ}45'</math></td> <td><math>200^{\circ}30'</math></td> </tr> <tr> <td>DE</td> <td><math>242^{\circ}45'</math></td> <td><math>62^{\circ}45'</math></td> </tr> <tr> <td>EA</td> <td><math>330^{\circ}15'</math></td> <td><math>147^{\circ}45'</math></td> </tr> </tbody> </table>	LINE	FB	BB	AB	$191^{\circ}45'$	$13^{\circ}0'$	BC	$39^{\circ}30'$	$222^{\circ}30'$	CD	$22^{\circ}45'$	$200^{\circ}30'$	DE	$242^{\circ}45'$	$62^{\circ}45'$	EA	$330^{\circ}15'$	$147^{\circ}45'$	
LINE	FB	BB																		
AB	$191^{\circ}45'$	$13^{\circ}0'$																		
BC	$39^{\circ}30'$	$222^{\circ}30'$																		
CD	$22^{\circ}45'$	$200^{\circ}30'$																		
DE	$242^{\circ}45'$	$62^{\circ}45'$																		
EA	$330^{\circ}15'$	$147^{\circ}45'$																		
<b>UNIT – II</b>																				
3 a)	Explain different types of leveling operations?	7																		
b)	When the reciprocal leveling is done? Describe the method along with a sketch.	7																		
<b>(Or)</b>																				
4 a)	In an operation of reciprocal leveling, two points A and B are taken on opposite banks of a river. When the level was set up near A, the staff readings on A and B are 3.235m and 4.250m respectively. When the level was set up near B, the respective staff readings are 2.345m and 3.623m. Find the true difference of level between A and B. What is the RL of B, if RL of A is 132.250?	7																		
b)	The following consecutive readings were taken with a level and 4m leveling staff on a continuously sloping ground at common intervals of 30m. 0.905(on A), 1.745, 2.345, 3.125, 3.725, 0.545, 1.390, 2.055, 2.955, 3.455, 0.595, 1.015, 1.850, 2.655 and 2.945(on B). The RL of A was 395.50 m. calculates RLs of different points and find the gradient of line AB.	7																		
<b>UNIT – III</b>																				
5 a)	Derive an expression for Simpson's rule for computing area between boundary and chain line.	7																		
b)	The following are the perpendicular offsets were taken from a chain line to a hedge																			



	Calculate area by (1) Trapezoidal rule (2) Simpsons rule Distance(m) _ 0 5 10 15 20 30 40 50 65 Offset (m) _ 3.40 4.25 2.60 3.70 2.90 1.80 3.20 4.50 3.70	7
	<b>(Or)</b>	
6 a)	A railway embankment of formation width of 8m and side slope 2:1 is to be constructed. The ground level along the centre line is as follows: Chainage _ 0 50 100 150 200 250 GL (m) _ 115.75 114.35 116.80 115.20 118.50 118.25 The embankment has a raising gradient of 1 in 100 and the formation level at zero chainage is 115.00. Assuming the ground is level across the centre line, Compute the volume of the earth work.	10
b)	The areas enclosed by the contours in a lake are as follows: Contour (m) _ 270 275 280 285 290 Area (m <sup>2</sup> ) _ 2050 8400 16300 24500 31500 Calculate the volume of water between the contours 270m and 290m by: (i) Trapezoidal formula and (ii) Prismoidal rule	4
	<b>UNIT - IV</b>	
7 a)	Describe the method of setting a circular curve by Rankin's deflection angle method	7
b)	Two tangents intersect at a chainage of 1000m, the deflection angle being 30 <sup>0</sup> . Calculate all the necessary data for setting out a circular curve of offsets from the chord produces, taking a peg interval of 25m.	7
	<b>(Or)</b>	
8 a)	Write the procedure to find horizontal and vertical angles using Total station instrument.	7
b)	What are the functions and principles involved in Total station instrument?	7
	<b>UNIT - V</b>	
9 a)	What are different types of photogrammetry?	7
b)	What is flight planning and stereoscopy?	7
	<b>(Or)</b>	
10 a)	Explain electro-magnetic spectrum.	7
b)	What are platforms and sensors? Write different types of platforms and sensors?	7

**K S R M College of Engineering (Autonomous), KADAPA – 516 003**  
**B. Tech III Semester Regular Examinations, Model Question Paper- 2021**  
**Sub: Building Materials and Constructions**  
**(Civil Engineering)**

Time: 03:00 Hrs.

Max.

Marks: 70

---

**Note: Answer All Questions. Each question will carry equal marks**

**Unit-I**

1. Briefly describe the following.

7+7 M            (a) Dressing of stone (b) Quarrying

Or

2. Describe the classification of Bricks as per Indian standards. How do they compare on their properties?

14 M

**Unit-II**

3. What are the types of cement explain clearly? Write the properties of Cement.

6+8 M

Or

4. Write an essay Mortar.

14 M

**Unit-III**

5. (a) What are the good characteristics of Paints.

7 M

(b) Types of Paints

7 M

Or

6. Classification and properties of Glass .

14 M

**Unit-IV**

7. Differences between Stone Masonry and Brick Masonry.

14 M

Or

8. Explain in detail Types of Walls.

14 M

**Unit-V**

9. Describe types of Doors and Windows.

14 M

Or

10. What are the Methods of DPC? Explain Cleary wherever with neat sketches.  
14 M

\*\*\*\*\*

Code: (1803303)

K.S.R.M COLLEGE OF ENGINEERING, KADAPA (AUTONOMOUS)

B.Tech III SEMESTER (R18) Regular Examinations, 2021

BASIC MECHANICAL ENGINEERING

*(CIVIL ENGINEERING)*

Model Question Paper

Time:3 hours

Max Marks: 70

Answer any five questions. Selecting one question from each unit

All questions carry equal marks

**UNIT I**

1. (a) Derive the expression for  $p dv$  work for polytropic process. (7 Marks)
- (b) Explain the equation of state for perfect gas? (7 Marks)

**OR**

2. Explain Kelvin Plank and Clausius statements of the second law of Thermodynamics (14 Marks)

**UNIT II**

3. (a) Explain with neat sketch the working of Babcock and Wilcox boiler. (7 Marks)
- (b) Explain the working of four stroke petrol engine. (7 Marks)

**OR**

4. Explain the Components and Working Of Centrifugal Pump & reciprocating pump? (14 Marks)

**UNIT III**

5. (a) Explain about refrigerator, heat engine, and heat pump with neat diagrams. (7 Marks)
- (b) What is psychrometry .Explain the following terms
- [a] specific humidity [b] Dry bulb temperature
- [c] Degree of saturation (7 Marks)

**OR**

- 6 Explain the working of vapour compression refrigeration system with neat diagram (14 Marks)

**UNIT IV**

7. (a) Explain the working of hydro electric power plant with neat sketch. (14 Marks)
- OR**
8. (a) Write the mechanical properties of materials. (7 Marks)

**(b)** Describe thermal power station with a neat sketch?

(7Marks)

**UNIT V**

**(9)** what is mechanism. Explain whit worth quick return motion mechanism with neat diagram  
(14Marks)

**OR**

**(10)** Explain different types of operations performed on lathe machine ? (14Marks)

**Model Question paper**

B.Tech., III Sem (R18)

NUMERICAL METHODS, PROBABILITY & STATISTICS

(Common to CE & ME Branches)

Time: 3 Hrs.

Max Marks: 70

Note: Answer any **FIVE** questions by choosing one from each unit.

All questions carry equal marks.

**Unit - I**

1. (a) Solve the equation  $x^3 - 9x + 1 = 0$  by using the bisection method. (7M)

(b) Solve the equation  $\cos x = xe^x$  by using the Regula - falsi method. (7M)

(OR)

2. Solve the system of equations  $83x + 11y - 4z = 95$ ,  $7x + 52y + 13z = 104$ ,  $3x + 8y + 29z = 71$  by Gauss-Seidel iteration method. (14M)

**Unit- II**

3. Calculate the values of  $f(22)$  and  $f(42)$  from the following data. (14M)

$x$	20	25	30	35	40	45
$f(x)$	354	332	291	260	231	204

(OR)

4. Construct  $y(x)$  from the following data and hence find  $y(3)$ . (14M)

$x$	0	1	2	5
$y(x)$	2	3	12	147

**Unit-III**

5. (a) Out of 800 families with 5 children each, how many would you expect to have (i) 3 boys (ii) either 2 or 3 boys? Assume equal probabilities for boys and girls. (7M)

(b) A car-hire firm has two cars which it hires out day by day. The number of demands for a car on each day is distributed as a Poisson distribution with mean 1.5. Calculate the proportion of days (i) on which there is no demand, (ii) on which demand is refused. ( $e^{-1.5} = 0.2231$ ) (7M)

(OR)

6. Fit a normal curve to the following distribution. (14M)

$x$	2	4	6	8	10
$f$	1	4	6	4	1

**Unit- IV**

7. (a) An intelligence test was administered to a large group of boys who score on the average of 64.5 marks. The same test was given to a group of 400 boys they score an average of 62.5 marks with a standard deviation of 12.5 marks. Examine if the difference is significant. (7M)

(b) Random samples of 400 men and 600 women were asked whether they would like to have a fly over near their residency. 200 men and 325 women were in favour of the proposals. Test the hypothesis that proportions of men and women in favour of the proposal are same at 5% level. (7M)

8. (a) The research investigator is interested in studying whether there is a significant difference in the salaries of MBA grades in two metropolitan cities. A random sample of size 100 from Mumbai yields on average income of Rs 20,150. Another random sample of 60 from Chennai

results in an average income of Rs 20,250. If the variances of both the populations are given as  $\sigma_1^2 = Rs\ 40,000$  and  $\sigma_2^2 = Rs\ 32,400$  respectively. (7M)

- (b) An examination of the works of particular author in Tamil reveals that 3% of the words used were of Sanskrit origin. A passage containing 10,000 words. In one of the later works of the same author 250 words were found to be of Sanskrit origin. Does this indicate any significant change to the author's attitude about the use of Sanskrit words. (7M)

### Unit-V

9. (a) The means of two random samples of sizes 9 and 7 are 196.42 and 198.82 respectively. The sums of the squares of the deviations from the mean are 26.94 and 18.73 respectively. Can the samples be considered to have been drawn from the same normal population? (7M)

- (b) Two sample of sizes 9 and 8 given the sum of squares of deviations from their respective means equals to 160 inches square and 91 inches square respectively. Can they be regarded as drawn from the same normal population. (7M)

(OR)

10. (a) A sample analysis of examination results of 500 students was made. It was found that 220 students had failed, 170 had secured a third class, 90 were placed in second class and 20 got a first class. Do these figures commensurate with the general examination result which is in the ratio of 4:3:2:1 for the various categories respectively. (7M)

- (b) Given the following contingency table for hair colour and eye colour. Find the value of  $\chi^2$ . Is there good association between the two? (7M)

Hair colour \ Eye colour	Fair	Brown	Black	Total
Blue	15	5	20	40
Grey	20	10	20	50
Brown	25	15	20	60
Total	60	30	60	150

**Q.P. Code: 1823301/1823401**

**K.S.R.M. COLLEGE OF ENGINEERING :: KADAPA  
(AUTONOMOUS)**

**B.TECH –III/ IV SEMESTER(R-18) REGULAR EXAMINATION OF APRIL/MAY 2020-  
2021**

**SUB: BIOLOGY FOR ENGINEERS  
(Common to EEE,MECHANICAL & CIVIL)  
(Common to CSE & ECE)**

**Time: 3:00 Hours**

**Max.Marks:70**

**ANSWER ONE QUESTION FROM EACH UNIT  
ALL QUESTIONS CARRY EQUAL MARKS**

			Marks	CO	BL
<b>UNIT –I</b>					
1	a.	Discuss the structure of a cell in detail	7	CO2	L2
	b.	Illustrate the different types of plant tissues	7	CO3	L3
(OR)					
2	a.	Describe the process of cell cycle	7	CO2	L2
	b.	What are the parts and functions of animal cell? Explain.	7	CO3	L3
<b>UNIT –II</b>					
3	a.	What are carbohydrates? Discuss its broad classification.	7	CO4	L4
	b.	Explain the double helix structure of DNA with a neat diagram.	7	CO4	L4
(OR)					
4	a.	State the structure of proteins.	7	CO4	L2
	b.	Define enzymes and state its applications in industry.	7	CO4	L2
<b>UNIT –III</b>					
5	a.	Elaborate the different classes of nutrients and their deficiency diseases.	7	CO5	L3
	b.	Distinguish between aerobic and anaerobic respiration.	7	CO2	L2
(OR)					
6	a.	Discuss about the human physiology of excretory system.	7	CO3	L3
	b.	Examine the steps involved in physiology of human digestive system.	7	CO2	L5
<b>UNIT –IV</b>					
7	a.	Describe the structure of prokaryotic gene.	7	CO3	L3
	b.	Outline the Insulin production .	7	CO4	L4
(OR)					
8	a.	Explain the process of replication of DNA	7	CO4	L4
	b.	Describe the steps involved in the process of transcription in eukaryotes	7	CO3	L3
<b>UNIT –V</b>					
9	a.	What are the different types of antibodies? Discuss its role in immunity.	7	CO4	L4
	b.	State the advantages and disadvantages of transgenic plants (Bt Cotton).	7	CO4	L5
(OR)					
10	a.	How the Dolly sheep was cloned? Explain the steps involved in cloning Dolly.	7	CO4	L4
	b.	Explain the basic principles and applications of biosensors.	7	CO4	L3



**K S R M College of Engineering (Autonomous), KADAPA – 516 003**  
**B.Tech IV Semester (R18) Regular Examinations, Model Paper, 2020**  
**Sub: DISASTER PREPAREDNESS AND PLANNING MANAGEMENT**  
**(Civil Engineering)**

**Time: 03:00 Hrs.**

**Max. Marks: 70**

**Note: Answer All Questions. All questions carry equal marks**

	<b>UNIT – I</b>	
1	a.) Define Hazard and Disaster?	7
	b.) Define Vulnerability and risks severity.	7
	<b>(Or)</b>	
2	Illustrate the classification of disasters	14
	<b>UNIT – II</b>	
3	Write a note on manmade landslides. State the mitigation measures at the time of landslides.	14
	<b>(Or)</b>	
4	Write short notes on i). cyclones ii). Floods iii). Drought iv). soil erosion	14
	<b>UNIT – III</b>	
5	(a) Explain briefly about impacts of transportation accidents? (b) Explain about volcanic types based on shape?	7 7
	<b>(Or)</b>	
6	Discuss the hazard and vulnerability profile of India.	14
	<b>UNIT – IV</b>	
7	Explain briefly about Disaster management cycle?	14
	<b>(Or)</b>	
8	Discuss the Post-disaster environmental response?	7 7
	<b>UNIT - V</b>	
9	Explain about Roles and responsibilities of government, community, local institutions, NGOs and other stakeholders.?	14
	<b>(Or)</b>	

10	What are Policies and legislation for disaster risk reduction?	14
----	--	----

**K S R M College of Engineering (Autonomous), KADAPA – 516 003**  
**B. Tech IV Semester Regular Examinations, (R18) Model Question Paper- 2020**  
**Sub: Engineering Geology (Civil Engineering)**

Time: 03:00 Hrs.

Max. Marks: 70

**Note: Answer All Questions. All questions carry equal marks**

Q No	UNIT – I	Marks
1	(a) Define Geology? Describe Various Branches of Geology and their importance in Civil Engineering Field. (b) A Brief note on Scope of Geology	8 6
	<b>(Or)</b>	
2	Define Weathering? Explain with neat sketches Weathering of Rock.	14
	<b>UNIT – II</b>	
3	(a) What is the Classification of Minerals? (b) Write the following physical properties of Minerals? (a) Mica (b) Hematite	7 7
	<b>(Or)</b>	
4	Write an Essay Physical Properties of minerals for Identification.	14
	<b>UNIT – III</b>	
5	(a) Explain briefly about Formation of Igneous Rocks? (b) Describe the following Rocks Physical characteristics (a) Basalt (b) Conglomerate	7 7
	<b>(Or)</b>	
6	Write an essay with neat sketches Textures of Igneous Rocks	14
	<b>UNIT – IV</b>	
7	Difference between dip & Strike? Explain with neat sketches Classification of Fold?	14
	<b>(Or)</b>	
8	(a) What are the causes of Rocks Deformations (b) Enumerate How to Recognize Fault? What are the classifications of Faults?	4 10
	<b>UNIT - V</b>	
9	Write an Essay Earthquake?	14
	<b>(Or)</b>	
10	(a) What are the Geological considerations of selection of Dams? (b) Application of Dams.	8 6

**K.S.R.M. COLLEGE OF ENGINEERING, (AUTONOMOUS) KADAPA**  
**B.Tech 1V SEMESTER EXAMINATION, APRIL 2020**  
**CIVIL ENGINEERING**  
**SUBJECT: EFFECTIVE TECHNICAL COMMUNICATION**

**Time : 3 Hrs.****Maximum Marks: 70**

Answer FIVE questions, choosing ONE question from each Unit.

All questions carry equal marks.

**UNIT - 1**

1. What are various types of communication, barriers of communication and methods of overcoming communication barriers? 14M

**(OR)**

2. A) Define communication and mention its objectives. 7M  
 B) List out essentials of good communication. 7M

**UNIT – 2**

3. What is technical writing process and mention steps to be followed in technical writing process? 14M

**(OR)**

4. (A) Discuss style and language in technical writing. 7M  
 (B) How do basics of grammar help in effective technical report writing? 7M

**UNIT – 3**

5. Continuous assessment is essential for self-development- Discuss with various aspects of self-development. 14M

**(OR)**

6. (A) Discuss time management. 7 M  
 (B) Support hints for career planning. 7 M

**UNIT – 4**

7. Write a technical report on feasibility of establishment of KIA Motors showroom in Kadapa. 14 M

**(OR)**

8. (A) What is Group Discussion? What are the essentials of effective group discussion? 7 M  
 (B) What are the guidelines preparing for an interview? 7 M

**UNIT – 5**

9. Role and responsibilities of an engineer in the development of the nation? 14 M

**(OR)**

10. (A) Discuss e-mail etiquettes. 7 M  
 (B) Engineering Ethics. 7 M

-----

Note: Answer All Questions. All questions carry equal marks

UNIT – I		
1	(a) List of the properties of fluids and explain in brief. (b) Explain the phenomenon of capillarity obtain an expression for capillary rise of a liquid	7m 7m
(Or)		
2	State and prove Newton's law of viscosity. Explain the effects of temperature and pressure on viscosity	14m
UNIT – II		
3	(a) Explain the different methods of measuring pressure devices (b) State and prove the pascal's law	7m 7m
(Or)		
4	Derive an expression for hydrostatic force and centre of pressure for inclined plane surface	14m
UNIT – III		
5	(a) Explain types of flows (b) Define stream function and velocity potential function and write short notes on flow net	7m 7m
(Or)		
6	(a) Define the rate of flow and derive the continuity equation	7m

	(b) A 30cm diameter pipe conveying water, branches in to two pipes of diameters 20cm and 15cm respectively. If the average velocity in 30cm diameter pipe is 2.5m/s, find the discharge in this pipe and also determine the velocity in 15cm pipe. If the average velocity in 20cm dia pipe is 2m/s	7m
UNIT – IV		
7	Derive the equation of Bernoulli's equation for stream line and from Euler's equation and write the applications of Bernoulli's and its principles	14m
(Or)		
8	A 45° reducing bend is connected to a pipe line the diameter at inlet and outlet of the bend 600mm and 300mm respectively find the force exerted by the water on the bed. If the intensity of pressure at inlet to the bend is $8.829 \times 10^4 \text{ N/m}^2$ and the rate of flow of water is 600 lit/sec	14m
UNIT - V		

9	(a) Define the Dimensionless numbers and their types. Brief explanation about their types (b) Water is flowing through a pipe of diameter 30cm at a velocity of 4m/s. Find the velocity of oil flowing in another pipe of diameter 10cm, if the condition of dynamic similarity is satisfied between the two pipes. The viscosity of water and oil is given as 0.01 poise and 0.025 poise. The specific gravity of oil = 0.8.	7m 7m
<b>(Or)</b>		
10	Derive the Buckingham's $\pi$ – theorem	14m

### MODEL QUESTION PAPER

K.S.R.M.College of Engineering (Autonomous), Kadapa

B.Tech. IV SEM (R18) CIVIL ENGINEERING

Sub: **MANAGERIAL ECONOMICS AND FINANCIAL ANALYSIS**

Time : 3Hrs.

Max.Marks : 70

\*Answer any **Five** Questions choosing one question from each unit.

\* All Questions carry Equal marks.

#### UNIT – I

1) Define Managerial economics. Explain its Nature and Scope ? 14M

(or)

2) a) Measurement of Elasticity of demand

7M

b) Explain statistical methods in demand fore costing

7M

#### UNIT – II

3) a) What are ISOQUANTS and ISOCOST ?

7M

b) What are the Internal economics of scale ?

7M

(or)

4) What is cost Analysis ? Explain in detail about fixed, variable and Marginal cost. 14M

#### UNIT – III

5) What is perfect competition ? How the price determined under condition of perfect competition ?

14M

(or)

6) Write about pricing and method of pricing.

14M

#### UNIT – IV

7) What are the merits and demerits of sole proprietor ship ?

14M

(or)

8) a) What are the Capital budgeting methods ?

4M

b) A CO. is considering to invest into a project that cost of 50,000/-. The project is likely to generate the following expected CFs.

10M

Years.	1	2	3	4	5
--------	---	---	---	---	---

CF's(.000)	10,000	10,000	15,000	15,000	20,000
------------	--------	--------	--------	--------	--------

**UNIT – V**

- 9) a) Define Double entry bookkeeping ? write detail advantages 4M  
 b) Enter the following transactions in the journal of kumar swamy. 10M

Year/ days.	Particulars	Rs.,
2009 March 1.	Commenced business with cash	28,000
2.	Brought goods for cash	18,000
3.	Paid wages	200
5.	Paid for stationary	100
8.	Purchase goods from Rama	16,000
9.	Goods returned to Rama	1,500
11.	Goods sold to Bhaskar	4,000
16.	Received cash from Bhanu	4,000

(or)

- 10) What are important Ratios ? Explain any five of them with examples. 14M

**K S R M College of Engineering (Autonomous), KADAPA – 516 003**  
**B. Tech IV Semester Regular Examinations, (R18)Model Paper, 2020**  
**Sub: SOLID MECHANICS-1**  
**(Civil Engineering)**

Time: 03:00 Hrs.

Max. Marks: 70

**Note: Answer All Questions. All questions carry equal marks**

<b>UNIT – I</b>		
1	Find the young's modulus of a rod of diameter 30mm and of length 3000mm which is subjected to a tensile load of 60kN and the extension of the rod is equal to 0.4mm.	14
<b>(Or)</b>		
2	Derive an expression for volumetric strain for a rectangular bar which is subjected to three mutually perpendicular tensile stress.	14
<b>UNIT – II</b>		
3	(a)What are the different types of beams? Differentiate between overhanging and simply supported beam. (b)Draw the S.F and B.M diagrams for simply supported beam of length L carrying a point load W at its middle point.	7 7
<b>(Or)</b>		
4	A simply supported beam of length 8m carries point loads of 4kN and 6kN at a distance of 2m and 4m from the left end . Draw the S.F and B.M diagrams for the beam.	14
<b>UNIT – III</b>		

5	(a) What do you mean by simple bending or pure bending? What are the assumptions made in the theory of simple bending? (b) Define the term: bending stress in a beam ,neutral axis and sectional modulus	7 7
	<b>(Or)</b>	
6	A steel plate of width 60mm and of thickness 10mm is bent in to a circular arc of radius 10m. Determine the maximum stress induced and the bending moment which will produce the maximum stress .Take $E=2 \times 10^5 \text{ N/mm}^2$ .	7 7
	<b>UNIT – IV</b>	
7	Find an expression for deflection at any section of a simply supported beam with an eccentric point load .using Macaulay’s method.	14
	<b>(Or)</b>	
8	A wooden beam 4m long ,simply supported at its ends , is carrying a point load of 7.25 kN at its centre .The cross section of the beam is 140mm wide and 240mm deep. If E for the beam $=6 \times 10^3$ , find the deflection at the centre.	14
	<b>UNIT - V</b>	
9	(a) Define the term: Torsion , torsional rigidity and polar moment of inertia. (b) A solid shaft of 20mm diameter is used to transmit torque. Find the maximum torque transmitted by the shaft if the maximum shear stress induced in the shafts is $150 \text{ N/mm}^2$	7
	<b>(Or)</b>	
10	Derive an expression for the shear stress produced in a circular shaft which is subjected torsion. What are the assumptions made in the derivation?	14

**Subject Code:** 1801501

**R 18**

**K S R M College of Engineering (Autonomous), KADAPA – 516 003**  
**B. Tech V Semester - Regular Examinations, 2021 - Model Question Paper**  
**Sub: SOLID MECHANICS – II**  
**(Civil Engineering)**

**Time: 03:00 Hrs.**

**Max. Marks: 70**

Answer any FIVE Questions choosing One Question from each Unit.

All Questions carries equal marks

### UNIT-I

- The rectangular stress components of a point in three-dimensional stress system are defined as a  $\sigma_x = 20\text{Mpa}$ ,  $\sigma_y = -40\text{Mpa}$ ,  $\sigma_z = 80\text{Mpa}$ ,  $\tau_{xy} = 40\text{Mpa}$ ,  $\tau_{yz} = -60\text{Mpa}$ ,  $\tau_{xz} = 20\text{Mpa}$ . Determine the principal stresses and principal planes.

**OR**



2. In a steel member, at a point the major principal stress is  $200\text{MN/m}^2$  and the minor principle stress is compressive. if the tensile yield point of the steel is  $235\text{MN/m}^2$ . Find the value of the minor principal stress at which yielding will commence, according to each of the following criteria of failure.
  1. Maximum shear stress
  2. Maximum total strain energy
  3. Maximum shear strain energy. Take passion ratio 0.26.

## UNIT II

3. A cylindrical shell 100 cm long, and 25 cm in internal diameter having thickness of metal as 8 mm, is filled with a fluid at atmospheric pressure. If the additional fluid of  $30\text{ cm}^3$  is pumped in the shell. Take  $E = 200\text{ GPa}$  and  $\mu = 0.3$ . Also find the hoop stress induced.

### OR

4. A thick steel cylinder having an internal diameter of 100 mm an external diameter of 200 mm is subjected to an internal pressure of 55 M pa and an external pressure of 7 Mpa. Find the maximum hoop stress.

## UNIT III

5. Derive the expression for buckling load (or) crippling load when both ends of the column are fixed.

### OR

6. A built-up column consisting of rolled steel beam ISWB 300 with two plates 200 mm x 10 mm connected at the top and bottom flanges. Calculate the safe load the column carry, if the length is 3m and both ends are fixed. Take factor of safety 3  $f_c = 320\text{ N/mm}^2$  and  $\alpha = \frac{1}{7500}$   
Take properties of joist:  $A = 6133\text{ mm}^2$   $I_{XX} = 9821.6 \times 10^4\text{ mm}^4$ ;  $I_{yy} = 990.1 \times 10^4\text{ mm}^4$

## UNIT IV

7. Sketch the Core of symmetrical I-Section consisting a Web 400 mm x 30 mm and Flange 250 mm x 20 mm each in compression and tension region.

### OR

8. A short hollow cylindrical column carries a compressive force of 400 kN. The extremal diameter of the column is 200 mm and the internal diameter is 120 mm. Find the maximum permissible eccentricity of the load, if the allowable stresses are  $60\text{ N/mm}^2$  in compression and  $25\text{ N/mrn}^2$  in tension.

## UNIT V

9. Derive the formula for the deflection of beams due to unsymmetrical bending.

### OR

10. A 80 mm x 80 mm x 10 mm angle section shown in fig. is used as a simply supported beam over a span of 2.4 m. It carries a load of 400 kN along the line YG, where G is the centroid of the section. Calculate (i) Stresses at the points A, B and C of the mid – section of the beam Take  $E = 200\text{ GN/m}^2$

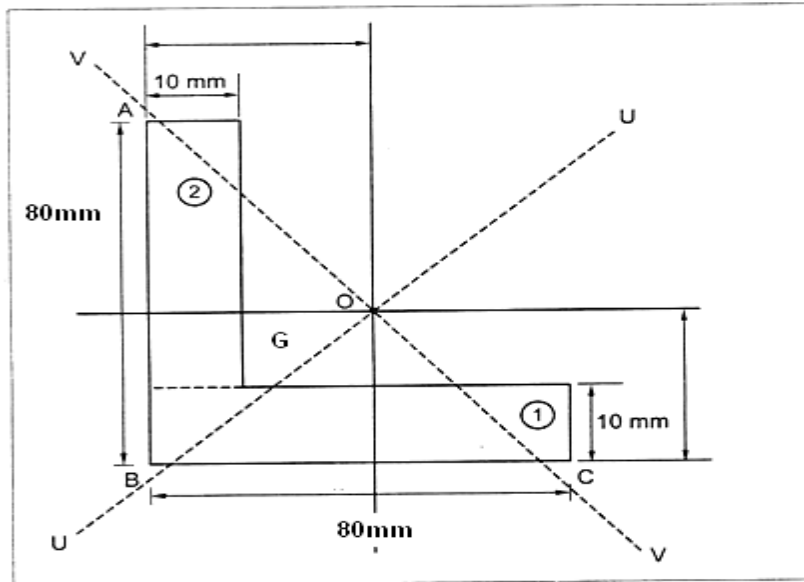

Subject Code: 1801502  
R18

K.S.R.M. COLLEGE OF ENGINEERING (AUTONOMOUS), KADAPA

V Sem (R18) – Model Question Paper - 2021

SUB: HYDRAULIC MACHINERY

(CE)

Time: 3 Hours

Max.

Marks: 70

Answer any FIVE Questions choosing one question from each unit.

All questions carry Equal Marks.

S.NO:	Questions	Marks		
<b>UNIT-I</b>				
1	A jet of water of diameter 100mm moving with a velocity of 30m/sec strikes a curved fixed symmetrical plate at the centre. Find the force exerted by the jet of water in the direction of the jet, if the jet is deflected through an angle of 120 degrees at the outlet of curved plate.	14		
<b>OR</b>				
2	Derive an expression for the calculation of critical depth in a triangular channel?	14		
<b>UNIT – II</b>				
3	A Pelton wheel has a mean bucket speed of 10 meters per second with a jet of water flowing at the rate of 700 liters/s under a head of 30 meters. The buckets deflect the jet through an angle of 160 degrees. Calculate the power given by the water to the runner and the hydraulic efficiency of the turbine. Assume Co-efficient of velocity as 0.98.	14		
<b>OR</b>				
4	Describe briefly the function of various main components of Pelton turbine with neat sketches?	14		

UNIT – III				
5	Explain the characteristics curves of Hydraulic turbines?	14		
OR				
6	Define the terms Unit speed of turbine, Unit power, Unit discharge, Unit quantities?	14		
UNIT – IV				
7	The internal and external diameter of the impeller of a centrifugal pump is 200 and 400mm respectively. The pump is running at 1200 r.p.m. The vane angles of the impeller at inlet and outlet are 20° and 30° respectively. The water enters the impeller radially and the velocity of flow is constant. Determine the work done by the impeller per unit weight of water.	14		
OR				
8	Define a centrifugal pump. Explain the working on a multi-stage centrifugal pump with sketches.	14		
UNIT – V				
9	What is reciprocating pump? Explain the principle and working of a reciprocating pump?	14		
OR				
10	A single-acting reciprocating pump, running at 50 R.P.M, delivers 0.01 m <sup>3</sup> /s of water. The diameter of the piston is 200 mm and strike length 400mm. Determine: i) The theoretical discharge of the pump, ii) Co-efficient discharge of the pump, iii) Slip and the percentage slip of the pump	14		

**Subject Code:** 1801503

**R 18**

**K S R M College of Engineering (Autonomous), KADAPA – 516 003**  
**B. Tech V Semester - Regular Examinations, 2021 - Model Question Paper**  
**Sub: STRUCTURAL ANALYSIS – I**  
**(Civil Engineering)**

**Time: 03:00 Hrs.**

**Max. Marks: 70**

Answer any FIVE Questions choosing One Question from each Unit.

All Questions carries equal marks

### UNIT-I

1. A fixed beam AB of length 6m carries point load of 160 kN and 120 kN at a distance of 2m and 4m from the left end A. Find the fixed end moments and the reactions at the supports. Draw B.M and S.F diagrams.

**OR**

2. Find the fixing moments and support reactions of a fixed beam AB of length 6m, carrying a uniformly distributed load of 4kN/m over the left half of the span.

### UNIT-II

3. A continuous beam consists of three successive span of 6m and 12m and 4m and carries load of 2kN/m, 1kN/m and 3kN/M respectively on the spans . Draw BMD and SFD for the beam. Find the support moments and plot the shear force and bending moment diagram by **Clayperon's theorem**.

**OR**

4. A continuous beam ABC is built-in at A and C and is carried over simple roller support at B. Span AB = 8.5 m and span BC = 7.5 m. It carries a uniformly distributed load of 17 kN/m over the span AB and a point load of 26 kN is acting in the span BC, 3.5 m from the middle support B. The middle support B sinks by 8 mm with respect to supports A and C. Find the moments and reactions at all the supports and draw the bending moment and shear force diagrams using **Clapeyorn's theorem** of three moments. Assume  $E = 2.1 \times 10^5$  MPa and  $I = 2.3 \times 10^{-3}$  m<sup>4</sup>.

### UNIT – III

5. Analyse the continuous beam shown in fig by **slope deflection method** and draw bending moment diagram.

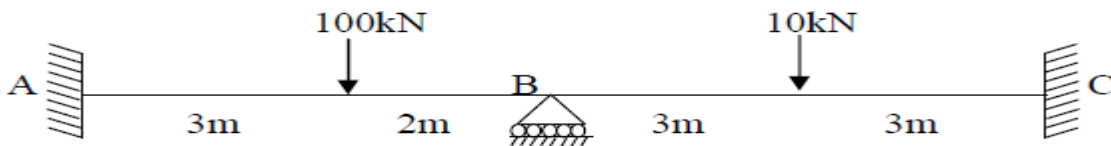

**OR**

6. Analyse the continuous beam shown in fig by **slope deflection method** and draw bending moment diagram.

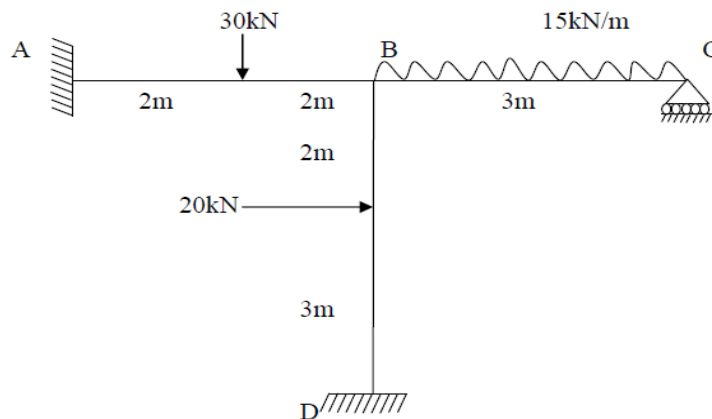

### UNIT IV

7. Determine the support moments and draw the bending moment diagram for a loaded beam shown in fig. Use **moment distribution method**. Ends A and D are fixed.

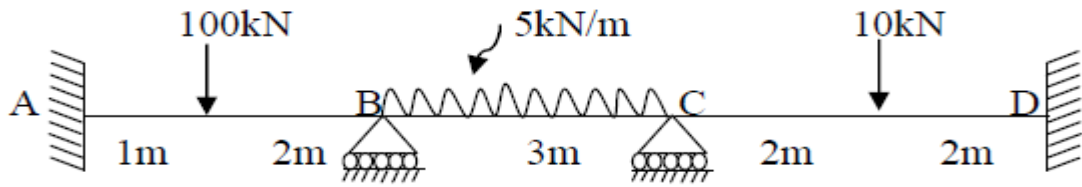

OR

8. Using **moment distribution method**, analyse the portal frame shown in figure below

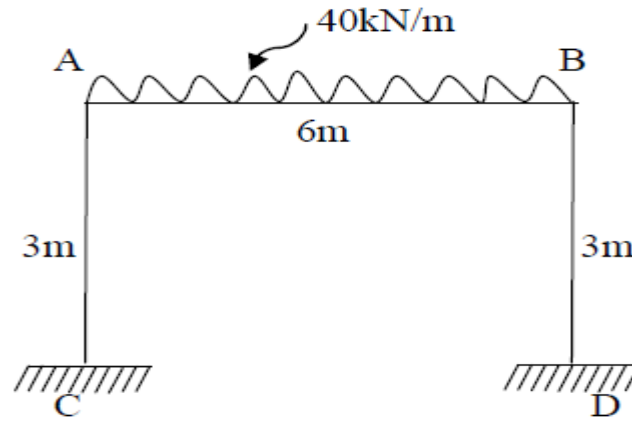

### UNIT V

9. Derive the expression for:

- (a) Strain energy due to axial load.
- (b) Strain energy due to flexural loading.

OR

10. Find the vertical deflection of the joint 'C' of the given truss.

Take  $E = 200 \text{ kN/mm}^2$ . The cross-sectional areas of:

- (i) Horizontal members =  $3000 \text{ mm}^2$ .
- (ii) Vertical members =  $4000 \text{ mm}^2$ .
- (iii) Inclined members =  $5000 \text{ mm}^2$ .

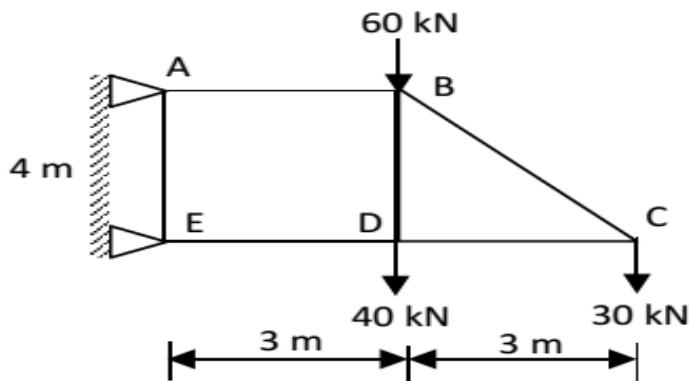

Model Question Paper  
 K S R M College of Engineering (Autonomous), KADAPA – 516 003  
**B.Tech (R 18) 5<sup>th</sup> Semester Regular Examinations, 2021 – Model Paper**  
**GEOTECHNICAL ENGINEERING**  
**(Civil Engineering)**

**Time: 03:00 Hrs.**

**Max. Marks: 70**

Note: 1. Answer FIVE questions, choosing ONE question from each UNIT  
 2. ALL questions carry EQUAL marks

**Unit - 1**

- 1 a Derive the relationship among dry density, bulk density and water content. 7 Marks  
 b Determine the IS classification of soil and percentage of materials present in. 7 Marks

IS Sieve	4.75 mm	2.00 mm	1.00 mm	600 $\mu$	425 $\mu$	300 $\mu$	150 $\mu$	75 $\mu$
Wt. retaining in 'g'	10	50	340	250	150	80	70	50

**Or**

- 2 a Distinguish between 7 Marks  
     i. Flow index and toughness index  
     ii. Air content and percentage air voids  
 b A fully saturated clay sample has a mass of 130 g and has volume of 64 cm<sup>3</sup>. The sample mass is 105 g after drying in oven. Assuming that volume does not change during drying. Determine specific gravity of soil solids, void ratio, porosity and dry density. 7 Marks

**Unit - 2**

- 3 a Describe the factors affecting permeability of soils. 7 Marks  
 b Explain about the pumping out test in unconfined and confined aquifers with a neat sketch. 7 Marks

**Or**

- 4 a Explain about quick sand condition with a neat sketch. 7 Marks  
 b Explain about the applications of flow nets. 7 Marks

**Unit - 3**

- 5 a Distinguish between Boussinesq and Westergaard theories of stress distribution in soils. 7 Marks  
 b A water tank has a circular foundation of 10 m diameter. If the total weight of tank with foundation is 2000 tons, calculate vertical stress at a depth of 2.5 m centrally below the foundation. 7 Marks

**Or**

- 6 a Describe the construction procedure of Newmark's influence chart. 7 Marks  
 b What is meant by pressure bulb? What is its significance? 7 Marks

**Unit - 4**

- 7 a Distinguish between standard and modified proctor compaction tests. 7 Marks  
 b The following data is obtained in IS light compaction test: 7 Marks

Water content (%)	2.0	4.2	5.5	6.6	7.5	10.0
Compacted density (g/cc)	2.02	2.08	2.17	2.20	2.21	2.20

Determine OMC and Maximum Dry Density. Also draw zero air voids line.

**Or**

- 8 a Derive differential equation for one dimensional consolidation as per Terzaghi's theory. 7 Marks
- b A 20 mm thick consolidated sample of clay reached 30 % consolidation in 20 minutes with double drainage. How long would it take for the clay layer from which sample is obtained, to reach 50 % consolidation? The clay layer is 5 m thick and has single drainage. 7 Marks

**Unit – 5**

- 9 a Explain Mohr-Coulomb theory of shear strength of soils 7 Marks
- b A specimen of sandy clay failed at a stress of 250 kN/m<sup>2</sup> in unconfined compression test. The failure plane was observed to make an angle of 35° with longitudinal axis of specimen. Determine shear parameters of soil. 7 Marks

**Or**

- 10 a Discuss merits and demerits of tri-axial test over direct shear test. 7 Marks
- b The following observations were made a sample of soil in tri-axial testing. 7 Marks

Test No.	Cell pressure (kN/m <sup>2</sup> )	Axial stress at failure (kN/m <sup>2</sup> )
1	300	875
2	400	1160
3	500	1460

Plot Mohr circles of stress and determine shear parameters.

**K.S.R.M COLLEGE OF ENGINEERING (AUTONOMOUS) – KADAPA – 516003**

**DEPARTMENT OF CIVIL ENGINEERING**

**B. Tech V Sem- R 18 – Regular Examinations – Model Paper- 2021**

**Sub: Environmental Engineering**

**Civil Engineering**

**Time: 3 Hours**

**Maximum Marks: 70**

**Answer any five questions, choosing one question from each unit.**

**All questions carry equal marks.**

**UNIT-I**

1. The census records of a city show population as follows:

Present		50,000
Before	one	47,100
decade		
Before	two	43,500
decades		
Before	three	decades
41,000		

Workout the probable population after one, two and three decades by using Arithmetical, Geometrical and Incremental increase method.

14M.

**(Or)**

2. (a) Define the term “per capita demand”. Write the factors affecting per capita demand and state the reasons for variations in demand. 7M

(b) The population figures of a town during the four decades i.e. 1960, 1970, 1980 and 1990 are 25,000, 30,500, 35,500 and 42,000 respectively. Predict its population in the year 2000 through Geometrical Increase method. 7M

### UNIT-II

3. Discuss the various Physical, Chemical and Biological characteristics of water. 14M

### OR

4. (a) Explain about Waterborne diseases and its causes 7M  
(b) Write the drinking water quality standards as per BIS. 7M

### UNIT-III

5. (a) Water has to be purified for a town whose daily demand is  $9 \times 10^6$  litres/day. Design a suitable sedimentation tank of the water works fitted with sludge remover. Assume the velocity of flow, in the sedimentation tank as 22cm/min and the detention period as 8 hrs. 7M  
(b) Discuss the Sedimentation by coagulation process using alum as coagulant. 7M

### OR

6. Design a rapid sand filter to treat 10 million liters of raw water per day allowing 0.5% of filtered water for backwashing. Half hour per day is used for backwashing. Assume necessary data. 14M

### UNIT-IV

7. (a) Write principles of functions of aeration process 07M  
(b) Write notes on : i) Membrane process ii) Desalination process 07M

### OR

8. (a) Write a note on iron removal from water for small communities 07M  
(b) Write about Rain water Harvesting methods 07M

### UNIT-V

- 9.(a) What are the different types of pipes in use for carrying water. Indicate approximately diameters and pressure ranges in which they are used. 07M  
(b) Explain and Sketch any two types of joints used for water mains. 07M

### OR

10. (a) Briefly explain about the different distribution networks to supply the water? 7M  
(b) What are the different methods of analyzing a given distribution system? Explain Hardy Cross method of pipe network analysis. 7M

**Subject Code:** 1801506

**R 18**

**K S R M College of Engineering (Autonomous), KADAPA – 516 003**  
**B. Tech V Semester - Regular Examinations, 2021 - Model Question Paper**  
**Sub: TRANSPORTATION ENGINEERING**  
**(Civil Engineering)**

**Time: 03:00 Hrs.**

**Max. Marks: 70**

---

Answer any FIVE Questions choosing One Question from each Unit.

All Questions carries equal marks

### UNIT – I

1. a.) Explain briefly about Engineering Surveys for Highway Alignment ? 7M



b.) Describe briefly about Road Network Patterns ?

7M

(or)

2. The following data were collected for planning the road development programme of a backward district.

Total area = 9600 km<sup>2</sup>, Agricultural and developed area = 3200 km<sup>2</sup>, Existing railway track length = 110 kms, Existing length of surfaced area = 322 kms, Existing length of unsurfaced area = 425 kms.

Number of Towns/villages in different population ranges are as below :

Population	> 5000	2001 - 5000	1001 - 2000	501 - 1000	< 500
No of Towns & villages	8	42	140	290	540

Calculate the additional length of surfaced and unsurfaced roads for the road system based on Nagpur road plan formulae for this district.

14M

### UNIT – II

3. a.) Write a short notes on different types of Sight distance ?

7M

b.) Calculate the safe stopping sight distance on a level road stretch for a design speed of 50 kmph for a.) Two way traffic on a single lane road

b.) Two way traffic on a Two lane road

Assume coefficient of friction as 0.35 and total reaction time of driver is 2.5 secs

7M

(or)

4. Explain briefly about the Transition curves ?

14M

### UNIT – III

5. a.) Write a short notes on Traffic speed studies ?

7M

b.) Describe briefly about Traffic Road Signs ?

7M

(or)

6. a.) Explain briefly about Accident Studies ?

7M

b.) The 15 minute traffic counts on cross roads 1 and 2 during the peak hour are observed as 170 and 145 vehicles per lane respectively approaching the intersection in the direction of heavier traffic flow. If the amber times required as 3 and 2 secs for the two loads based on approach speeds, design the signal timings by trial cycle method. Assume average time headway as 2.5 secs during the green phase ?

7M

### UNIT – IV

7. a.) Explain briefly about the types of Grade separated intersections ?

7M

b.) Write a short notes on the Advantages and Disadvantages of Rotary Intersections ? **7M**

(or)

8. Describe briefly about the Traffic Islands ? **14M**

**UNIT – V**

9. a.) Explain briefly about the Advantages and Limitations of the Flexible Pavements ? **7M**

b.) Describe briefly about the CBR test ? **7M**

(or)

10. a.) Write a short notes on the Types of joints in CC Pavements ? **7M**

b.) Explain briefly about the Factors affecting design and performance of CC pavements ?

**7M**

**Subject Code:** 1801510

**R 18**

**K S R M College of Engineering (Autonomous), KADAPA – 516 003**

**B. Tech V Semester - Regular Examinations, 2021 - Model Question Paper**

**Sub: REMOTE SENSING & GIS**

**(Civil Engineering)**

**Time: 03:00 Hrs.**

**Max. Marks: 70**

---

Answer any FIVE Questions choosing One Question from each Unit.

All Questions carries equal marks

**UNIT-I**

1. a) Explain in detail the spectral signatures of vegetation and soil. **6 M**

b) State the concept of resolution? Explain the spatial and radiometric resolutions in detail. **8 M**

(Or)

2. a) Describe the interaction of EMR with atmosphere. **8 M**

b) Describe the physics of Remote Sensing. **6 M**

**UNIT-II**

3. Explain the satellite and Sensor characteristics of IRS IC & ID **14 M**

(Or)

4. Explain various characteristics of sensors. **14 M**

**Unit- III**

5. a) Explain the elements of visual interpretation techniques. **8M**

b) Explain about Image enhancement **6M**

(Or)

6. Explain about spatial filtering and edge enhancement **14M**

**Unit – IV**

7. a) Define GIS. Describe the key components of GIS. **8M**

b) Explain Computational Analysis Methods (CAM). **6M**

(Or)

8. Explain in detail about functions of GIS. 14M

**UNIT- V**

9. Explain the applications of remote sensing in natural resource management 14M

**(Or)**

10. Explain the applications of remote sensing in water resources. 14M